

13. Aim your SS3 pods on each side, so that the top of the beam pattern is on the cutoff line mark.

14. Tighten the 5/32" allen bolts back down.

15. Reinstall the fog light covers and splash guard to complete the installation.

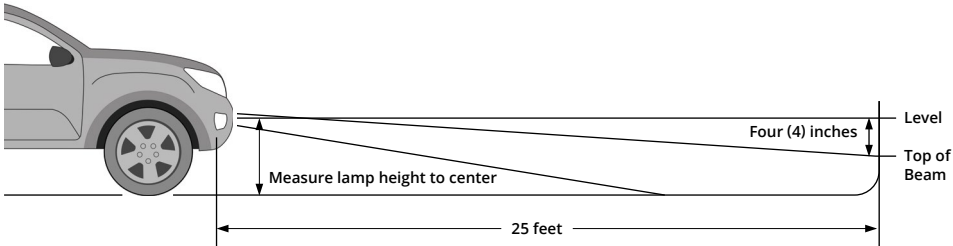

Please contact **Diode Dynamics** should you have any questions about the installation or wiring process, at **314-205-3033** (10a-5p CST) or [contact@diodedynamics.com](mailto:contact@diodedynamics.com).

**NEED MORE HELP?**

Scan the QR code to link to our YouTube Channel!

We continuously bring in vehicles to our testing garage in order to create step-by-step videos to walk you through the installation process on your specific vehicle. Scan the QR code to see all our installation videos. Be sure to subscribe to our channel to stay up-to-date on the newest products and videos from Diode Dynamics!

YouTube



**This installation guide is for the following SKUs:**

- DD6576** Worklight SS3 Sport Type MS Kit White SAE Driving
- DD6577** Worklight SS3 Sport Type MS Kit White SAE Fog
- DD6578** Worklight SS3 Sport Type MS Kit Yellow SAE Fog
- DD6579** Worklight SS3 Pro Type MS Kit White SAE Driving

- DD6580** Worklight SS3 Pro Type MS Kit White SAE Fog
- DD6581** Worklight SS3 Pro Type MS Kit Yellow SAE Fog
- DD6706** Worklight SS3 Max Type MS Kit White SAE Fog
- DD6707** Worklight SS3 Max Type MS Kit Yellow SAE Fog

**100% SATISFACTION**  
**GUARANTEE**



Thank you for your purchase of our new SS3 Type MS Foglight Kit. CAD-designed to use existing mounting points, this kit is compatible with the Jeep JL Wrangler and JT Gladiator Sport. Basic installation instructions are included below. **Please contact us if you have any questions.**

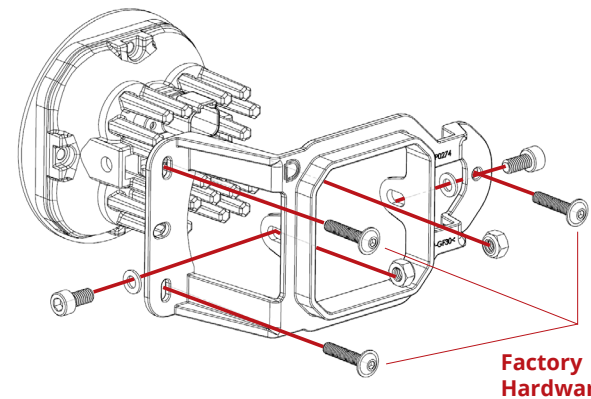

Left and Right Sides

1. Attach the bracket to the pod loosely, using one screw on each side. These screws will also determine the aim of your SS3 pods. See the diagrams above and to the right. Make sure the bracket is in the correct orientation.

COMPUTER DESIGNED  
**OEM FITMENT**

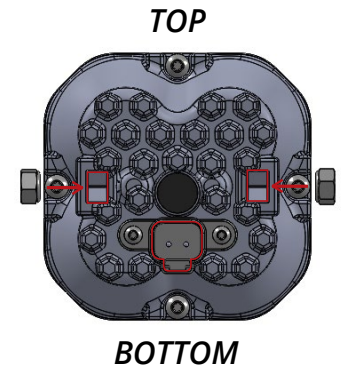

See inside for further instructions.

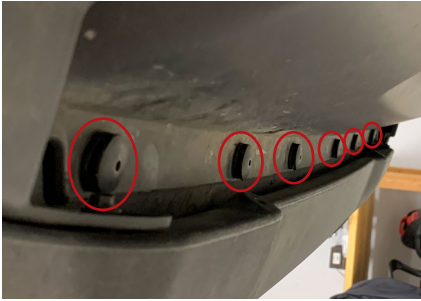

2. Using a trim removal tool, remove the eight push rivets along the front of the splash guard. We recommend prying on both accessible sides of the push rivets at the same time due to their large size.

Remove the splash guard. To do so, use an 8mm socket and ratchet to remove the two bolts on the bottom of the splash guard.

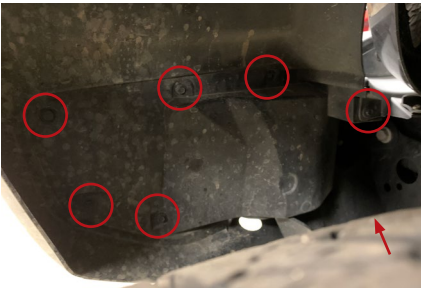

3. Remove the plastic fog light covers. To do so, use a 7mm socket and ratchet to remove the seven screws shown in the picture to the left.

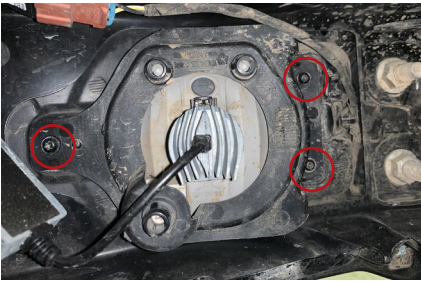

4. Remove the factory fog light assembly. Use a T20 Torx driver to remove the three screws. We recommend using hand tools to reduce the chance of thread stripping or heating of the plastic that may occur with power tools.

**These screws will be reused.**

5. Using the three original torx screws, install the SS3 and bracket onto the vehicle. Ensure the lamps are oriented such that the DT connector is on the "bottom" of the lamp and the SAE markings are readable when installed on the vehicle.

6. Plug the SS3 into the factory fog light harness using the included DT wire adapter. Test function. If the light does not turn on, try flipping the connector 180°.

7. Repeat the steps on the other side of the vehicle.

## Aiming Instructions



8. Park your vehicle 25 feet away from a wall or garage door on a level surface.



9. Loosen the 5/32" allen bolts on each side of your SS3 pod, just enough to allow you to adjust the pod.

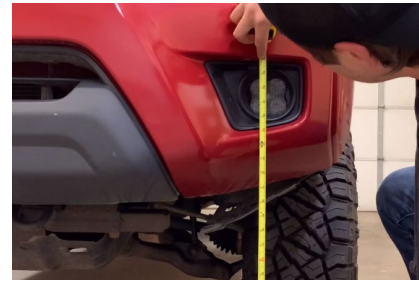

10. On your vehicle, measure the distance between the ground and the center of your SS3 pod. This is your mounting height.

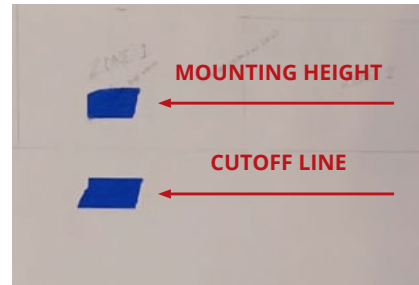

11. Mark the mounting height on the wall or garage door using tape.

12. Add another piece of tape four inches below the mounting height. This is your fog light cutoff line.

*See back for further instructions.*